

OVERHEAD CRANES, GANTRY CRANES, AND HOISTS

1. Purpose

- 1.1. To protect personnel from the hazards of working with and around overhead cranes, gantry cranes, and hoists and to establish inspection requirements.

2. Scope

- 2.1. This policy applies to all University personnel involved with working with and around overhead cranes, gantry cranes, and hoists.

3. Definitions

- 3.1. **Crane** - a machine for lifting and lowering a load and moving it horizontally, with the hoisting mechanism an integral part of the machine. Cranes whether fixed or mobile are driven manually or by power.
- 3.2. **Designated Person** – person selected or assigned by the employer as being qualified to perform specific duties.
- 3.3. **Gantry Crane** - a crane similar to an overhead crane except that the bridge for carrying the trolley or trolleys is rigidly supported on two or more legs running on fixed rails or other runway. (Appendix A)
- 3.4. **Hoist** - an apparatus which may be a part of a crane, exerting a force for lifting or lowering.
- 3.5. **Overhead Crane** - a crane with a movable bridge carrying a movable or fixed hoisting mechanism and traveling on an overhead fixed runway structure.
- 3.6. **Pendant** – control suspended from an electric hoist.
- 3.7. **Rated Load** - the maximum load for which a crane or individual hoist is designed and built by the manufacturer and shown on the equipment nameplate(s).
- 3.8. **Reeving** – to pass (a rope or similar item) through a hole, ring, or similar item.
- 3.9. **Sling** - an assembly which connects the load to the material handling equipment. (Appendix A)
- 3.10. **Trolley** - the unit which travels on the bridge rails and carries the hoisting mechanism.

4. Responsibilities

- 4.1. Risk Management and Safety shall:
 - 4.1.1. Maintain this written program to meet regulatory requirements and ensure it is current.
 - 4.1.2. Provide technical and program assistance to ensure the program is successfully implemented.



- 4.1.3. Provide crane, hoist, and lifting equipment awareness level training through eNDeavor.
- 4.1.4. Audit and revise the written Overhead Cranes, Gantry Cranes and Hoists procedure as necessary.
- 4.2. Department Managers/Supervisors shall:
 - 4.2.1. Ensure designated operators receive proper training.
 - 4.2.2. Ensure cranes, hoists, and slings are maintained in proper working order and repaired when necessary.
 - 4.2.3. Ensure cranes, hoists and slings are used in a safe manner.
 - 4.2.4. Ensure scheduled inspections and testing are conducted in accordance with manufacturer recommendations and applicable regulations.
- 4.3. Authorized crane/hoist contractor shall:
 - 4.3.1. Oversee the installation of all cranes and hoists.
 - 4.3.2. Conduct inspections and maintenance of cranes, hoists, and lifting equipment/hooks in accordance with manufacturer recommendations and applicable regulations. Report defects promptly to their supervisor so corrections can be made.

5. Design Requirements

- 5.1. All cranes and hoists shall be installed according to the manufacturer's specifications and applicable regulations.
- 5.2. Cranes and hoists may be modified or re-rated at any time as long as the modifications and associated structure is analyzed and approved by a qualified engineer or the crane manufacturer.
- 5.3. The rated load capacity of the crane and/or hoist and the associated structure shall be plainly marked on each side of the crane and be visible from the floor in a conspicuous location.

6. General Requirements

- 6.1. Cranes and hoists shall only be operated by the following designated personnel:
 - 6.1.1. Trained operators.
 - 6.1.2. Trainees under the direct supervision of a designated person.
 - 6.1.3. Authorized contractors completing maintenance and/or repairs.
- 6.2. The crane controller shall be located within convenient reach of the operator.
- 6.3. The trolley travel control shall be located so that the operator can readily face the direction of travel.
- 6.4. Push buttons shall automatically return to the "off" position when released by the operator.
- 6.5. Suspended loads shall be kept clear of all obstructions.
- 6.6. All employees shall be kept clear of loads about to be lifted and of suspended loads.

- 6.7. All hooks shall be equipped with a safety latch.
- 6.8. Slings
 - 6.8.1. Slings that are damaged or defective shall not be used.
 - 6.8.2. Slings shall not be shortened or lengthened by knotting or twisting.
 - 6.8.3. Sling legs shall not be kinked.
 - 6.8.4. Slings used in a basket hitch shall have the loads balanced to prevent slippage.
 - 6.8.5. Slings shall be securely attached to their loads.
 - 6.8.6. Slings that may come into contact with edges, corners, or protrusions shall be protected with a material of sufficient strength, thickness, and construction to prevent damage.
 - 6.8.7. A sling shall not be pulled from under a load when the load is resting on the sling.
 - 6.8.8. Slings shall not be loaded in excess of their recommended safe working load as prescribed by the sling manufacturer on the identification markings permanently affixed to the sling.
 - 6.8.9. Slings without affixed and legible identification markings shall not be used.
 - 6.8.10. Sling Inspections shall be performed each day before being used. The sling and all fastenings and attachments shall be inspected for damage or defects by a competent person.

7. Crane Operation Requirements

- 7.1. Pre-use inspection – At the start of each work shift (on a day when the crane will be used), operators shall complete a pre-use inspection in accordance with the steps listed in Appendix C or a document of similar format.
- 7.2. Rigging a load – When attaching a load to a crane, the following safety requirements shall be followed:
 - 7.2.1. Determine the appropriate size and number of slings and associated components.
 - 7.2.2. Pad sharp edges on loads being lifted/lowered to prevent wear on slings.
 - 7.2.3. Ensure slings and hooks are in proper working condition with no excessive wear.
 - 7.2.4. Determine the load's center of gravity and ensure rigging maintains the load in a level position during movement.
 - 7.2.5. Once slings are in place, lift the load slightly to test the rigging and balance. Re-work the rigging if necessary.
 - 7.2.6. Use a tag line when loads must traverse long distances or be otherwise controlled.
- 7.3. Lifting and lowering a load – During equipment moving operations the following safety requirements shall be followed:
 - 7.3.1. Only designated personnel may operate a crane.

- 7.3.2. The crane operator and signal person shall be able to communicate at all times. If audio (voice/radio) communication between the operator and signal person is not possible, hand signals shall be used. A list of standard hand signals is provided in Appendix B.
- 7.3.3. Ease the load up/down to prevent shock load on the crane. Shock load can occur when a suspended load is accelerated/decelerated quickly.
- 7.3.4. Lift loads only high enough to clear the tallest obstruction in the travel path.
- 7.3.5. Employees shall not be on the load when the load is being hoisted, lowered, or is traveling.
- 7.3.6. Employees shall stand clear of all overhead loads. Employees shall not pass under a suspended load.
- 7.3.7. Operators shall not carry loads over employees and shall ensure that the area of travel remains clear at all times during travel.
- 7.3.8. Never leave suspended loads unattended. In an emergency, if a load must remain suspended, ensure the area is clearly marked with signage and blocked on all four sides to prevent unauthorized access.
- 7.4. Parking a crane/hoist – Once loads are moved and the crane is out of operation for the shift, it shall be properly parked.
 - 7.4.1. Remove all slings and accessories from the hook and return rigging devices to designated storage locations.
 - 7.4.2. Raise the hook at least 7 feet above the floor.
 - 7.4.3. Store the pendant away from aisles and work areas, or raise it at least 7 feet above the floor.
 - 7.4.4. Place the emergency stop switch in the off position and place the controller in designated storage location to prevent unauthorized use.
- 7.5. Signal Persons
 - 7.5.1. A signal person must be used if any of the following conditions exist:
 - 7.5.1.1. The load travel pathway or the area near or at load placement is not in full view of the operator.
 - 7.5.1.2. View of the travel pathway is obstructed.
 - 7.5.1.3. The operator or the person handling the load determines that it is necessary due to site specific safety concerns.
- 7.6. All signal persons shall wear appropriate head, foot and hand protection.
- 7.7. Standard hand signals (Appendix B) shall be used by the signal person unless voice communication (e.g., telephone, radio, or equivalent) is utilized for lifts.
 - 7.7.1. Special operations may require additions or modifications to standard signals. They shall be agreed upon and understood by the signal person and the operator.
- 7.8. All communications shall be discernible or audible to the operator.

8. Inspections

- 8.1. Initial Inspection: New, repaired, or modified cranes and hoists shall be inspected by a qualified person prior to initial use in accordance with Periodic Inspection as described in Section 8.3.
- 8.2. Pre-use Inspection:
 - 8.2.1. Shall be conducted before each shift or each use, whichever occurs first.
 - 8.2.2. Hazards identified during a pre-use inspection shall be reported immediately.
- 8.3. Periodic Inspection:
 - 8.3.1. A documented inspection that includes observations of crane and hoist operation.
 - 8.3.2. A documented inspection that includes the observations of alloy steel chain slings.
 - 8.3.3. Shall be performed by an authorized contractor.
 - 8.3.4. Shall be performed annually unless otherwise determined by the authorized contractor performing maintenance or manufacturer's recommendations.
- 8.4. Inspections for Returning an Idle Crane to Service
 - 8.4.1. If a crane or hoist is idle for a period of 1 to 6 months, a documented pre-use inspection shall be performed on the crane before it is placed back in service.
 - 8.4.2. If a crane or hoist is idle for a period of over 6 months, a documented periodic inspection shall be performed on the crane before it is placed back in service.

9. Maintenance

- 9.1. A preventative maintenance program based on the crane manufacturer's recommendations shall be established.
- 9.2. Prior to maintenance beginning:
 - 9.2.1. The crane shall be run to a location where it will limit or prevent interference with surrounding operations and any cranes that may be located in the area.
 - 9.2.2. All controllers shall be switched to the off position.
 - 9.2.3. The main or emergency switch shall be locked in the open position in accordance with the University's Lock, Tag, Try procedure.
 - 9.2.4. Warning or "out of order" signs shall be posted on the crane and hook where it is visible from the floor.
- 9.3. Any unsafe conditions identified during pre-use and/or periodic inspections shall be corrected prior to resuming crane operation. Only authorized contractors shall make any adjustments or repairs.

10. Personal Protective Equipment

- 10.1. All persons working in proximity of a crane or hoist shall wear personal protective equipment in accordance with their completed [PPE Hazard Assessment](#).

11. Training

- 11.1. Only designated, trained persons are permitted to operate a crane.
- 11.2. Trainees may only operate a crane/hoist under the direct supervision of persons who have the knowledge, training, and experience to train operators and evaluate their competence and where such operation does not endanger the trainee or other employees.
- 11.3. The trainee shall be provided sufficient practical training exercises and time under the direct supervision of a qualified trainer/mentor.
- 11.4. At a minimum, training shall include:
- 11.4.1. Classroom/online training including:
 - 11.4.1.1. General crane safety
 - 11.4.1.2. Crane inspections
 - 11.4.1.3. Attaching, raising, lowering, and moving loads
 - 11.4.1.4. Hand signals
 - 11.4.2. Hands-on training: Operators shall be trained to safely operate the specific make and model(s) of crane they will be operating. Training shall include, the following:
 - 11.4.2.1. Crane controls
 - 11.4.2.2. Appropriate slings to use with loads
 - 11.4.2.3. Handling instructions detailed by the manufacturer
 - 11.4.2.4. Hand signals used while operating the crane
 - 11.4.3. Written examination: Both the classroom and hands-on training shall be validated by an examination process.
- 11.5. Classroom/online training shall be repeated every three (3) years following initial training to maintain competency.
- 11.6. Refresher training in relevant topics shall be conducted under the following circumstances:
- 11.6.1. The operator has been observed operating a crane or hoist in an unsafe manner.
 - 11.6.2. The operator/signal person has been involved in an accident or near-miss incident.
 - 11.6.3. The signal person has been observed displaying a lack of understanding of the hand signals.
 - 11.6.4. Changes to workplace conditions affecting the safe operation of the crane or hoist.
- 11.7. Hands-on training shall be conducted at a 1:1 trainer/trainee ratio.

- 11.8. Instructors and qualified trainers shall be knowledgeable of equipment operation, inspection procedures, basic maintenance, and applicable OSHA standards.

12. Record Retention

- 12.1. Records required by this procedure shall be retained for a minimum of three (3) years. This includes:
 - 12.1.1. Pre-use inspection documents.
 - 12.1.2. Periodic inspection documents.
 - 12.1.3. All maintenance records.

13. Procedure Evaluation

- 13.1. RMS shall conduct a documented audit of the Overhead Cranes, Gantry Cranes, and Hoists program once every three years.
- 13.2. The audit shall include:
 - 13.2.1. Review of crane/hoist inspection records,
 - 13.2.2. Verification that procedures are appropriate, understood, and implemented.
 - 13.2.3. Review of cranes and hoists maintenance records.
- 13.3. Revisions to the program or training process shall be made as a result of the audit as necessary.





14. Resources

- 14.1. The Occupational Safety and Health Administration, 29 CFR 1910.179.
Overhead and Gantry Cranes.
- 14.2. The Occupational Safety and Health Administration, 29 CFR 1926.1419.
Signal-General Requirements.
- 14.3. The Occupational Safety and Health Administration, 29 CFR 1910.184.
Slings.

Revision History Table



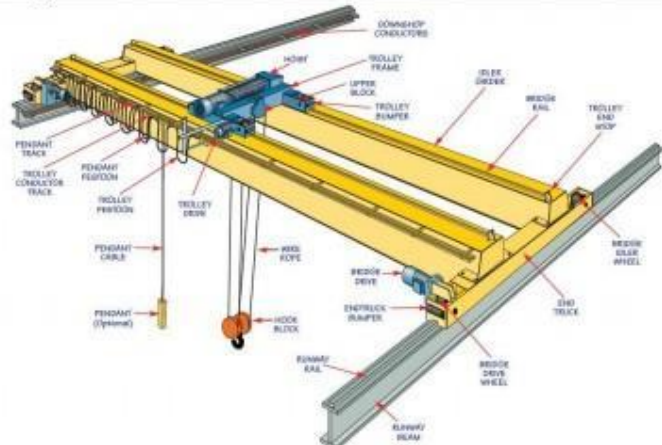



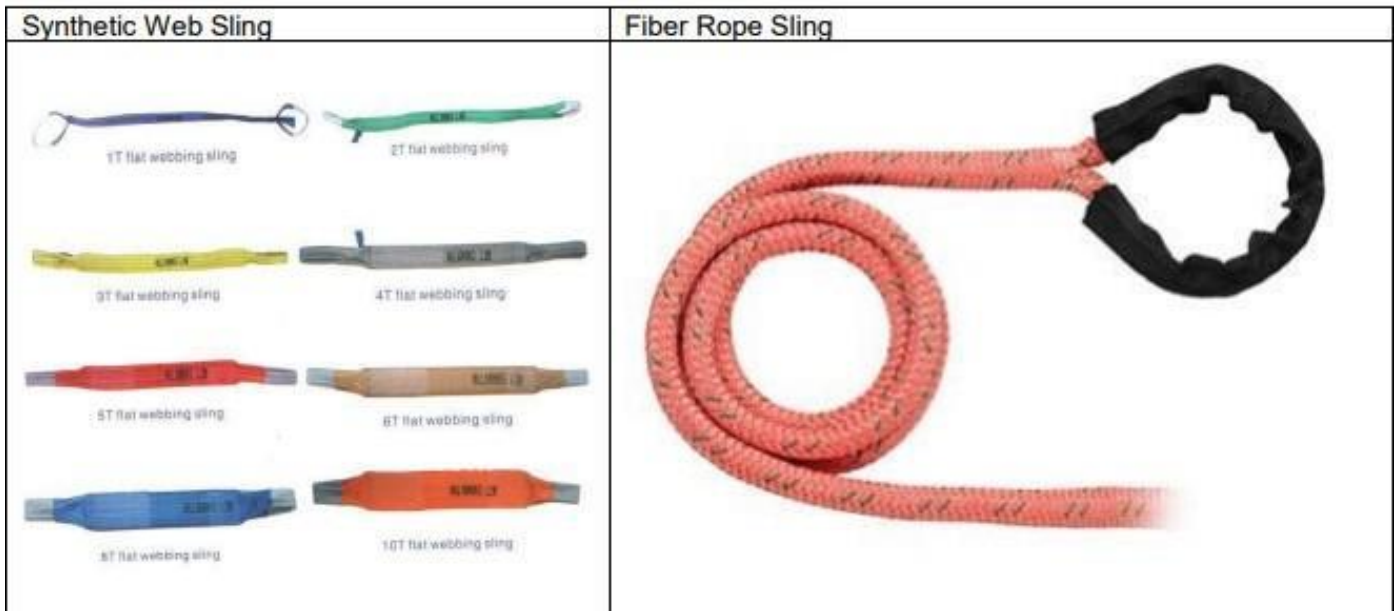
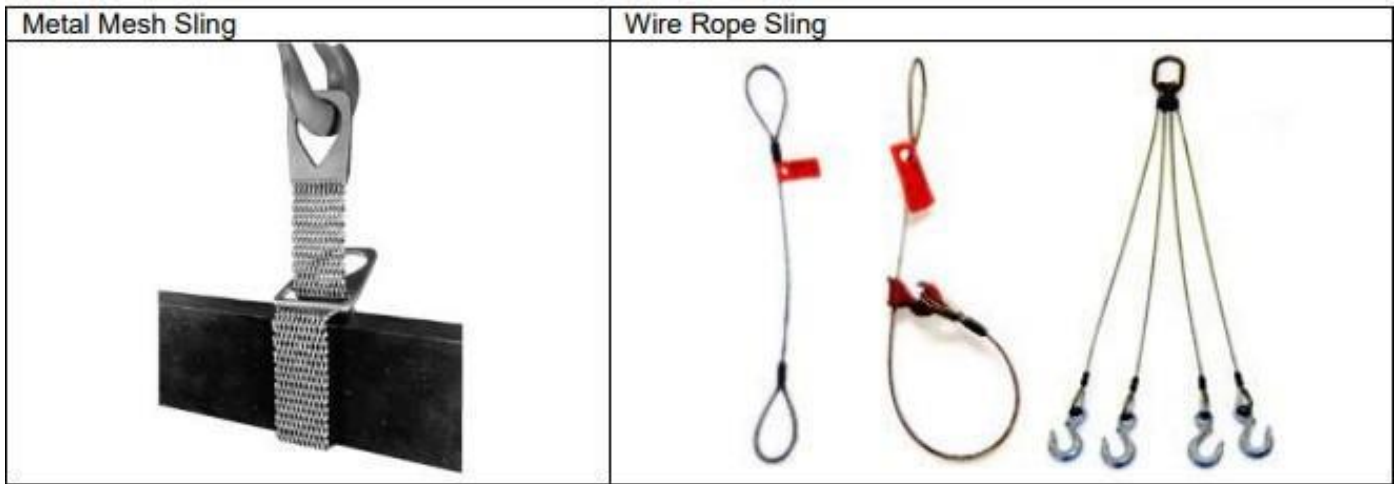
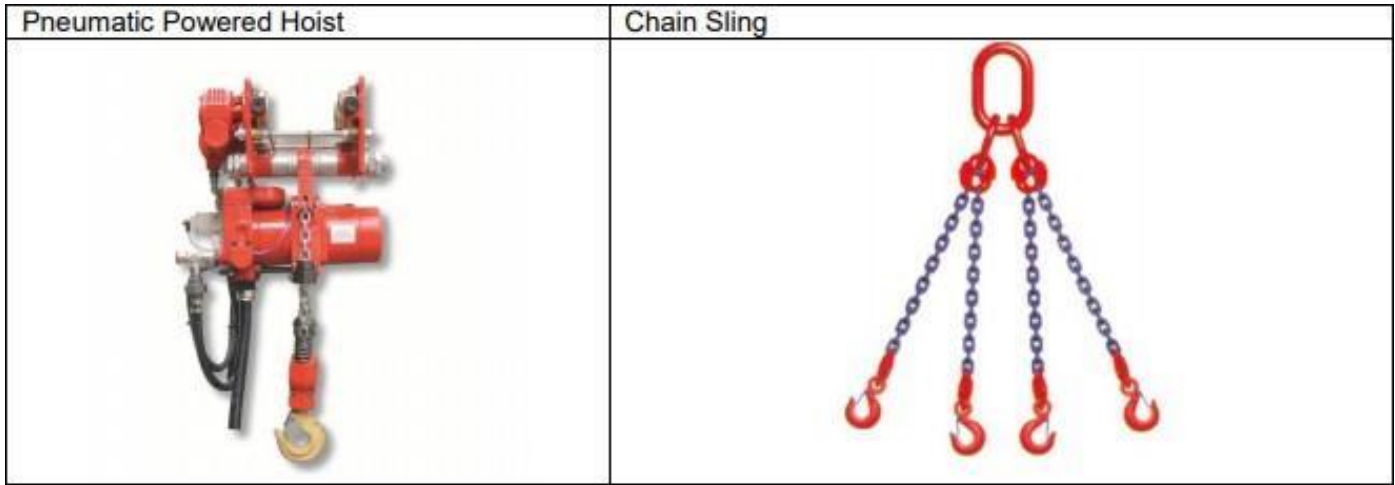

History	Effective Date
Created	March 2020
Approved	June 2020
Added section 8.3.2 to include the periodic inspection requirements on alloy steel chain slings.	July 2021
Added 6.9.10 Updated record retention 12.1 to specific time frame. Updated Appendix B images. Updated Appendix C verbiage, duplicated in Qualtrics for areas completing electronic Pre-Use inspection form.	June 2023



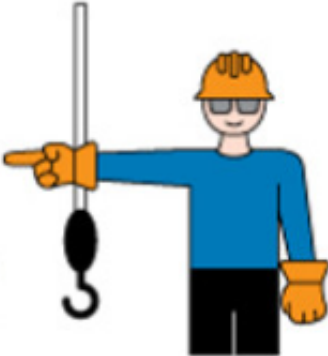

Appendix A. Different Types of Cranes, Hoists and Slings on Campus

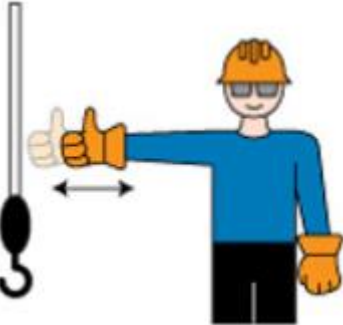

<p>Gantry Crane</p> 	<p>Semi-Gantry Crane</p> 
<p>Floor-Operated Crane</p> 	<p>Bridge Crane</p> 
<p>Electric Powered Hoist</p> 	<p>Manual Hoist (Lever, chain fall, come along)</p> 

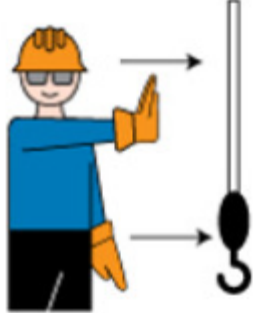
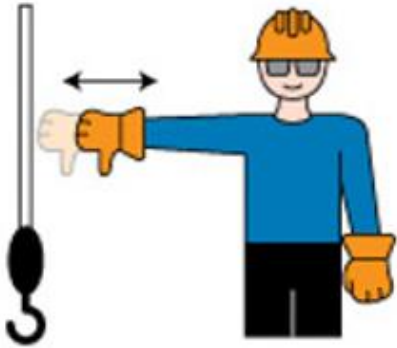

**Appendix B.
Signal Person Hand Signals**

 <p>STOP - With arm extended horizontally to the side, palm down, arm is swung back and forth.</p>	 <p>EMERGENCY STOP - With both arms extended horizontally to the side, palms down, arms are swung back and forth.</p>	 <p>HOIST - With upper arm extended to the side, forearm and index finger pointing straight up, hand and finger make small circles.</p>
 <p>RAISE BOOM - With arm extended horizontally to the side, thumb points up with other fingers closed.</p>	 <p>SWING - With arm extended horizontally, index finger points in direction that the boom is to swing.</p>	 <p>RETRACTING TELESCOPING BOOM - with hands to the front at waist level, thumbs point at each other with other fingers closed.</p>
 <p>RAISE THE BOOM & LOWER THE LOAD - With arm extended horizontally to the side and thumb point up, fingers open and closed while load movement is desired.</p>	 <p>DOG EVERYTHING - Hands held together at waist level.</p>	 <p>LOWER - With arm and index finger pointing down, hand and finger make small circles.</p>

 <p>LOWER BOOM - With arm extended horizontally to the side, thumb points down with other fingers closed.</p>	 <p>EXTEND TELESCOPING BOOM - With hands to the front at waist level, thumbs point outward with other fingers closed.</p>	 <p>TRAVEL/TOWER TRAVEL - With all fingers pointing up, arm is extended horizontally out and back to make a pushing motion in the direction of travel.</p>
 <p>LOWER THE BOOM & RAISE THE LOAD - With arm extended horizontally to the side and thumb pointing down, fingers open and close while load movement is desired.</p>	 <p>MOVE SLOWLY - A hand is placed in front of the hand that is giving the action signal.</p>	 <p>USE AUXILLARY HOIST (whipline) - With arm bent at elbow and forearm vertical, elbow is tapped with other hand. Then regular signal is used to indicate desired action.</p>

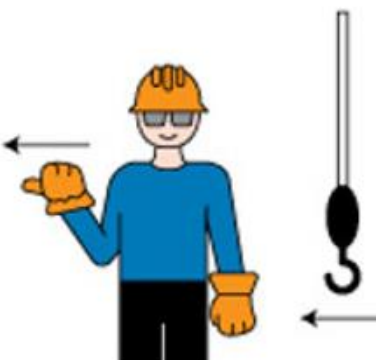
 <p>CRAWLER CRANE TRAVEL, BOTH TRACKS - Rotate fists around each other in front of body; direction of rotation away from body indicated travel forward; rotation towards body indicates travel backward.</p>	 <p>USE MAIN HOIST - A hand taps on top of the head. Then regular signal is given to indicate desired action.</p>	 <p>CRAWLER CRANE TRAVEL, ONE TRACK - Indicate track to be locked by raising fist on that side. Rotate other fist in front of body in direction that other track is to travel.</p>
 <p>TROLLEY TRAVEL - With palm up, fingers closed and thumb pointing in direction of motion, hand is jerked horizontally in direction trolley is to travel.</p>		



**Appendix C.
Pre-Use Inspection Checklist**

Hoist Make/Model:	Date:
--------------------------	--------------

Item	Description of Inspection Check Points	Pass	Fail	N/A
1. Tagged Crane or Hoist	The crane or hoist is not locked or tagged out.			
2. Control Devices	Test run controls to ensure they match device markings.			
3. Brakes	All motions do not have excessive drift and that stopping distances are normal.			
4. Hook	No damage, cracks, nicks, gouges, deformations of the throat opening, wear on saddle, or load bearing point and twist.			
5. Hook Latch	Operates properly and does not have damage.			
6. Wire Rope/Chain	No broken wires, strands, kinks, or other deformation or damage.			
7. Reeving	The wire rope or chain is properly reeved and are not twisted about each other.			
8. Limit Switches	Check that the upper limit device stops lifting motion.			
9. Oil Leakage	Check for any sign of oil leakage on crane and on the floor area beneath the crane.			
10. Unusual Sounds	No unusual sounds from the crane or hoist mechanism while operating the crane or hoist.			
11. Warning & Safety Labels	Warning and other safety labels, e.g., load capacity, are not missing and are legible.			
12. Housekeeping & Lighting	Check area for accumulated material, slip/trip hazards, and poor lighting.			
13. Slings and all fasteners	Check for damage or defects.			

Notes/Deficiencies:

Inspector Signature: _____